



THE ULTIMATE TOP ENTRY ENCLOSURE WEATHER RESISTANT—VANDAL RESISTANT

- 100% stainless steel construction assures long-term, rustproof durability and additional strength
- Three-point locking mechanism and heavy duty continuous hinge ensures maximum security
- 38" height with flip top access provides for ease of viewing and programming
- Louvers at top and bottom allow cross flow ventilation
- Filter screens deflect errant water spray and protect against entry of dirt and insects
- Dual pistons allow for easy opening and closing of lid
- Easy access to predrilled removable backboard
- Ten year limited warranty
- NEMA 3R rated

SB-16SS 16" Wide Top Entry Enclosure

- 16" Wide, 38" High, 15.5 Deep
- 100% Stainless Steel
- Weather & Vandal Resistant
- UL Listed
- NEMA 3R Rated
- Three-Point Locking System
- Removable, Predrilled Backboard
- Large Door-Mounted Storage
- Louvered For Ventilation

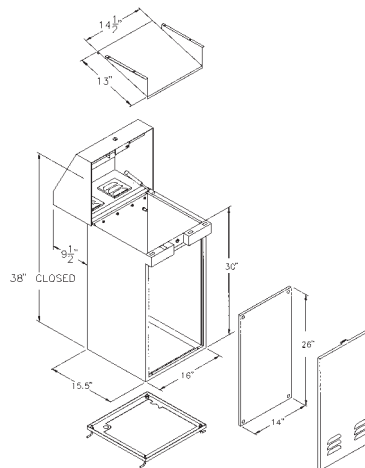

SB-22SS 24" Wide Top Entry Enclosure

- 24" Wide, 38" High, 17" Deep
- 100% Stainless Steel
- Weather & Vandal Resistant
- UL Listed
- NEMA 3R Rated
- Three-Point Locking System
- Removable, Predrilled Backboard
- Large Door-Mounted Storage
- Louvered For Ventilation

