



COLD ROLLED STEEL ENCLOSURE WEATHER RESISTANT—VANDAL RESISTANT

- Cold rolled steel construction assures long-term, rustproof durability and strength
- Three-point locking mechanism, flush-mounted access handle and heavy duty continuous stainless steel hinge ensures security
- Removable, predrilled backboard provides for easy installation and an attractive finished product
- Powder coated finish in dark green color
- Large door-mounted storage area provides easy access to plans and scheduling information
- Filtered side louvers at bottom and top allow cross flow ventilation
- One year limited warranty
- NEMA 3R rated

SB-18CR 18" Wide Enclosure

- 18" Wide, 36" High, 12" Deep
- Stainless Steel Hinge
- Weather & Vandal Resistant
- UL Listed
- NEMA 3R Rated
- Three-Point Locking System
- Removable, Predrilled Backboard
- Large Door-Mounted Storage
- Louvered For Ventilation

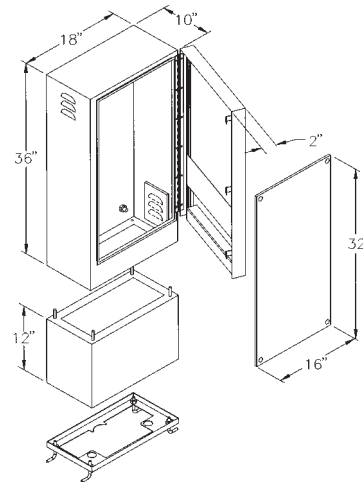

SB-24CR 24" Wide Enclosure

- 24" Wide, 36" High, 12" Deep
- Stainless Steel Hinge
- Weather & Vandal Resistant
- UL Listed
- NEMA 3R Rated
- Three-Point Locking System
- Removable, Predrilled Backboard
- Large Door-Mounted Storage
- Louvered For Ventilation

