



**COMBINED COMMERCIAL METER SOCKET
WITH THE ULTIMATE ENCLOSURE**

- Compact, double door, front and back design, provides viewing and programming convenience
- 100% stainless steel construction assures long-term, rust-proof durability and additional strength
- Chameleon effect of the natural brushed stainless steel finish provides an unobtrusive quality

METER SECTION

- UL listed, E.U.S.E.R.C. approved commercial meter socket, 100 amp rated, with test block bypass provision
- Hinged viewing window provides convenient access for metering agency
- 100 amp load center
- 120v and 240v models available

ENCLOSURE SECTION

- Removable, predrilled backboard provides for easy installation and an attractive finished product
- Large door-mounted storage area provides easy access to plans and scheduling information
- Side louvers at bottom and top allow crossflow ventilation
- Ten year limited warranty

**SB-24SS/120V
Metered Enclosure 120 Volt**

- 24" Wide, 48" High, 29" Deep
- 120 Volt Meter Socket
- Test Blocks
- 8 Position Load Center
- Double Door Design
- 12" Deep Storage on Back Side
- 100% Stainless Steel
- Weather & Vandal Resistant
- Three-Point Locking System
- Removable, Predrilled Backboard
- Large Door-Mounted Storage
- Louvered For Ventilation
- UL Listed
- NEMA 3R Rated

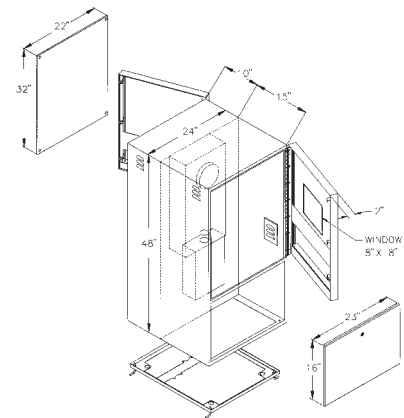

**SB-24SS/240V
Metered Enclosure 240 Volt**

- 24" Wide, 48" High, 29" Deep
- 240 Volt Meter Socket
- Test Blocks
- 8 Position Load Center
- Double Door Design
- 12" Deep Storage on Back Side
- 100% Stainless Steel
- Weather & Vandal Resistant
- Three-Point Locking System
- Removable, Predrilled Backboard
- Large Door-Mounted Storage
- Louvered For Ventilation
- UL Listed
- NEMA 3R Rated

