



## VANDAL-RESISTANT EASY ACCESS BACKFLOW ENCLOSURE

- Marine grade aluminum alloy construction provides lasting durability and strength, with light weight for ease of handling
- 100% stainless steel hardware assures long-term, rust proof durability and additional strength
- Full release locking mechanism requires no tools and provides easy access for service and repair
- Flush-mounted locking mechanism and solid sheet construction ensures maximum security
- Chameleon effect of the natural finish provides an unobtrusive quality
- Pre-punched viewing ports provide for easy inspection without removing the cover
- Expansion module allows for length adjustments to meet field requirements
- Five year limited warranty

### Low Profile Enclosure

	"A" Length	Height	Width
SBBC-15AL	15"	29.5"	16.25"
SBBC-30AL	30"	29.5"	16.25"
SBBC-45AL	45"	29.5"	16.25"
SBBC-60AL	60"	29.5"	16.25"

Note: For inside dimensions, see Backflow Cover Sizing Chart on page 18.

- Marine Grade Aluminum
- Stainless Steel Hardware
- Weather Resistant
- Patented Locking System Accepts Padlock
- Removable Without Tools

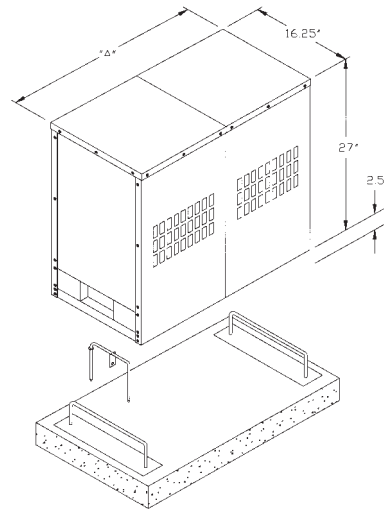

### High Profile Two Piece Enclosure

	"A" Length	Height	Width
SBBC-40AL	40"	39"	24"
SBBC-60AL	60"	39"	24"
SBBC-75AL	75"	39"	24"
SBBC-90AL	90"	39"	24"

Note: For inside dimensions, see Backflow Cover Sizing Chart on page 18.

- Marine Grade Aluminum
- Stainless Steel Hardware
- Weather Resistant
- Patented Locking System Accepts Padlock
- Removable Without Tools

